

**E6 Ranheim – Værnes**

**Søknad om tillatelse til  
etablering av deponi – M3  
Malvik**

Vedlegg 6 – Beredskapsplan og risikovurdering



# E6 Ranheim - Væres

## HS PLAN VÆRE AREA



### RECORD OF REVIEWS

Document code	Status	Date revised	Date approved	Description
E6RV-ACC-HS-PLN-00005		29/09/2020	29/09/2020	First version OH&S Plan for Være area

Produced by:		Revised by:		Approved by:	
Name:	JSL	Name:	ON	Name:	FVS
Position:	HSE Manager	Position:	Site Manager	Position:	Project Director
Signature: <b>SIGNED</b>		Signature: <b>SIGNED</b>		Signature: <b>SIGNED</b>	



## INDEX

---

<b>1</b>	<b>DOCUMENT CHANGE LOG</b> .....	<b>3</b>
<b>2</b>	<b>PURPOSE AND SCOPE</b> .....	<b>3</b>
<b>3</b>	<b>IMPLEMENTATION PLAN</b> .....	<b>5</b>
<b>4</b>	<b>DELINEATION/FENCES</b> .....	<b>5</b>
<b>5</b>	<b>FACILITIES</b> .....	<b>6</b>
<b>5.1</b>	<b>OFFICE</b> .....	<b>6</b>
<b>5.2</b>	<b>INDUCTION ROOM</b> .....	<b>6</b>
<b>5.3</b>	<b>DINNING ROOM</b> .....	<b>6</b>
<b>5.4</b>	<b>TOILETS</b> .....	<b>7</b>
<b>5.1</b>	<b>DRESSING ROOM</b> .....	<b>7</b>
<b>5.2</b>	<b>STORAGE ROOM</b> .....	<b>7</b>
<b>5.3</b>	<b>FIRST AID FACILITY</b> .....	<b>7</b>
<b>6</b>	<b>TRAFFIC MANAGEMENT</b> .....	<b>7</b>
<b>7</b>	<b>ORGANIZATION CHART</b> .....	<b>7</b>
<b>8</b>	<b>ACCESS TO THE SITE</b> .....	<b>8</b>
<b>8.1</b>	<b>Document control system</b> .....	<b>8</b>
<b>8.2</b>	<b>Induction training</b> .....	<b>8</b>
<b>8.3</b>	<b>Control access</b> .....	<b>9</b>
<b>8.4</b>	<b>Visitor</b> .....	<b>9</b>
<b>8.5</b>	<b>COVID19 Control Access Management</b> .....	<b>9</b>
<b>9</b>	<b>REGISTER, TIMETABLE AND SHIFT</b> .....	<b>9</b>
<b>10</b>	<b>HSE DIGITAL DEVIATION – SAFETY OBSERVATION CARD</b> .....	<b>9</b>
<b>11</b>	<b>EMERGENCY</b> .....	<b>10</b>
<b>12</b>	<b>RISK ASSESSMENT / MAIN RISK</b> .....	<b>12</b>



## 1 DOCUMENT CHANGE LOG

Rev.	Change
00005-00	First version HS Plan for Være Area

## 2 PURPOSE AND SCOPE

This HS Plan, supported by the main Occupational Health and Safety Management Plan, is applicable to all works carried out by ACCIONA and its subcontractors, consultants or other such organizations involved at the Være area: Chainage 4+600.

Sequence of works:

1. Upgrading access road.
2. Vegetation and clearing
3. Rock cut ( earth works ).
4. Rock cut ground support.
5. Final layout temporary rig area.
6. Utilities works

The Environmental Plan and Traffic Plan will be developed separately.

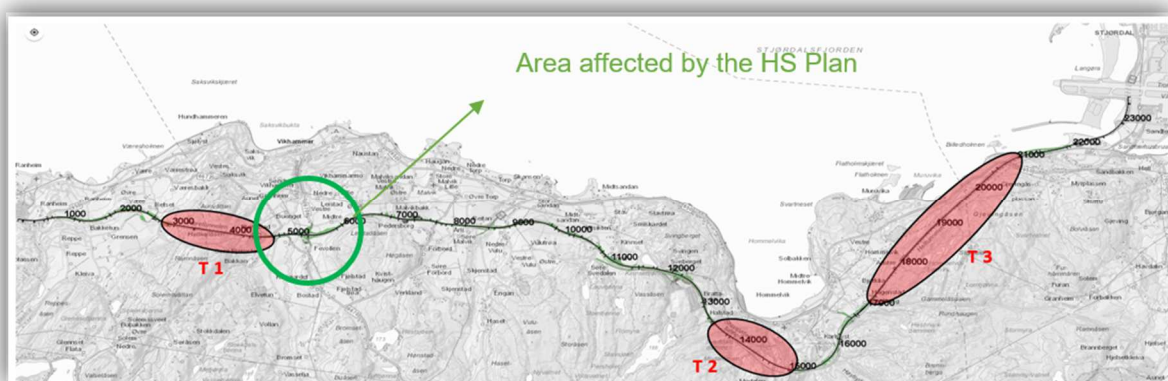

Figure 1. Relevant area for this HS Plan



Figure 2. Areas A and B to be filled mainly with tunnels excavation material

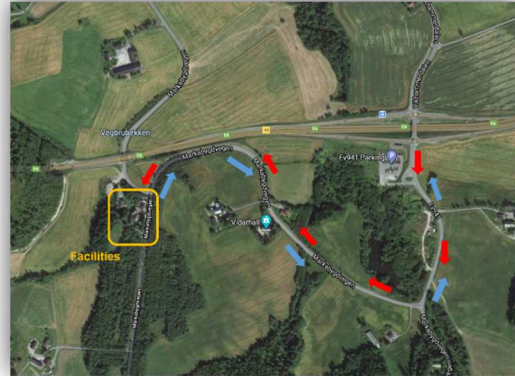

Figure 3. Main access to the site and facilities

This Plan, jointly with the HS Management Plan, defines the OHS measures which ACCIONA will implement on site.

This HS Plan is a live document and will be subjected to modifications during all phases of the project to ensure that the lessons learned are adopted in the management and control of Health and Safety.

The scope of application of the current HS Plan, together with the OHS Management Plan, does not extend to other companies contracted directly by the Client, nor to any possible subcontractor companies, that must carry out their work in the same premises or area where ACCIONA will work. Non-compliance on part of said companies with current occupational safety and health standards shall not be attributed to ACCIONA. It is the responsibility of those companies to establish the necessary work and coordination guidelines.

Note: The rig area will be partially created with the tunnel excavation material and with the cut material from the slopes. The rig area will be often adapting to scope of work.



### 3 IMPLEMENTATION PLAN

Two different stages have been considered in the Være implementation:

#### FIRST STAGE.

In the first stage are included the works required before tunnel excavation commences, which are listed in section 2 of this document. This is the scope of this H&S Plan. For the tunnel works, a separate H&S Plan will be developed or the currently HS Plan will be updated.

The image below shows the proposed rig area:

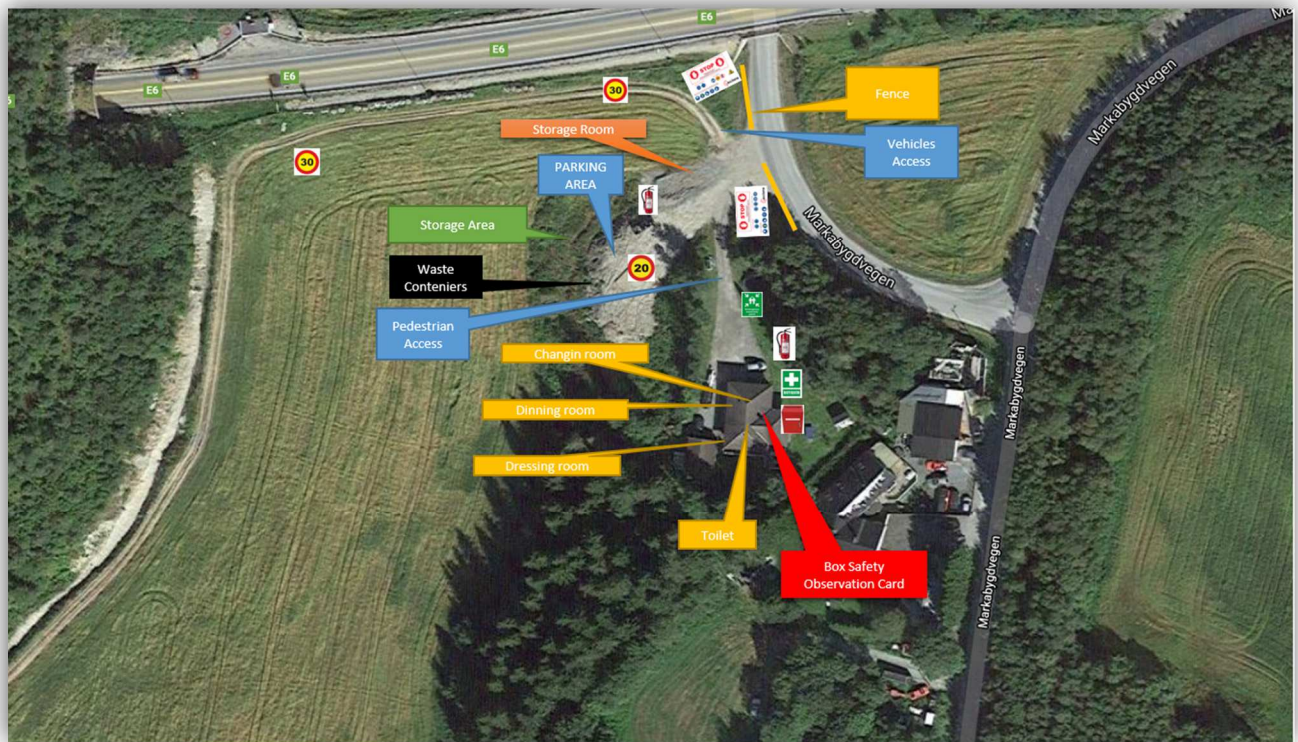

#### SECOND STAGE.

An implementation drawing for a second stage (during tunneling works) will be included in here in a future revision of this Plan.

### 4 DELINEATION/FENCES

The site will be fenced by fences which sizes will be 3 m. \* 2 m. There will be two different accesses. One for pedestrians and one for machinery, plant and equipment.





*Machinery access signals*



*Pedestrian access sign*

## 5 FACILITIES

### 5.1 OFFICE

No site offices at the first stage are planned to be installed in the area. The main office located in Ranheim (Vikelvfaret 4, 2<sup>nd</sup> floor) will be temporarily the office for this area. Existing houses owned by Nye Veier will be in the future Acciona site offices.

### 5.2 INDUCTION ROOM

No induction room at the first stage is planned to be installed in the area. Induction training will be realized at the main office located in Ranheim ( Vikelvfaret 4, 2<sup>nd</sup> floor). One of the existing houses owned by Nye Veier will be adapted in the future to an Acciona site induction room.

### 5.3 DINNING ROOM

No dining room at the first stage is planned to be installed in the area. Existing houses owned by Nye Veier will be in the future adapted to an Acciona site dining room.



It will be furnished with:

Table + chairs + Refrigerator + microwave (microwave oven)

## 5.4 TOILETS

No permanent toilets at the first stage are planned to be installed in the area. Meanwhile portable toilets will be placed on site. Existing houses with toilets owned Nye Veier will be used in a future stage.

## 5.1 DRESSING ROOM

No dressing room at the first stage is planned to be installed in the area. Existing houses owned by Nye Veier will be in the future adapted to an Acciona site dressing room.

## 5.2 STORAGE ROOM

A storage room will be installed with a size of 20 \* 10 m, once the initial works are finished. This is not applicable to the starting works. It will be required but on a later stage.

## 5.3 FIRST AID FACILITY

A first aid kit will be available on site to assist, just in case, an emergency categorized small. Site cars will also be provided by small first aid kit in.

## 6 TRAFFIC MANAGEMENT

It is not required at this stage of the works. It will be developed for the entrance/exit to Markabygdvegen

## 7 ORGANIZATION CHART

The following OHS organization chart will be applicable to the site:

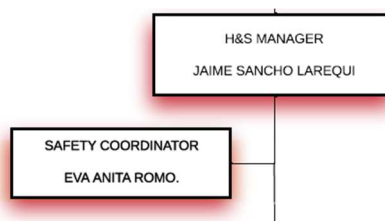





## 8 ACCESS TO THE SITE

### 8.1 Document control system

An access control system in terms of documentation will be implemented on site. Only subcontractors which have uploaded the documentation in the Platforms (Nalanda and HMSREG), including company, worker and machinery documentation, will be allowed to access to the site to perform the works which has been hired for. Once the documentation has been assessed and validated, the traffic light in the Platform is in green color. Temporary, the access control to the site will be addressed filling in a daily bases the crew list template.



### 8.2 Induction training

ACCIONA has established an obliged induction training for all the workers who can access to the site to perform the work, except for the visitor which will receive a brief induction visitor training.

TIMETABLE: Adapting to the circumstance. Normally from 09:00 – 11:00 every morning.

LOCATION: Vikelvfare 4, Ranheim. Once the existing houses owned by Nye Veier are available, an induction room will be prepared for that purpose, if it is required.

Workers without the mentioned induction training will not be allowed to access to the site.

Once the worker has passed the induction exam, an "induction sticker" will be issued to fix it to the worker helmet.





### 8.3 Control access

There will not be physical control access at the Være area except when tunnel works take place. The workers will access to the site using the gate installed for it. Also the machinery will access to the site through the gate installed for it but not barrier will be installed.

### 8.4 Visitor

Visitor´s access shall be done escorted by a person of the site. It is not allowed to access to the site freely without being escorted.

Every visit must be registered at the site, fulfilling a specific visitor register template.

### 8.5 COVID19 Control Access Management

To follow the Norwegian Health and Safety Public Administration rules for construction works.

<https://www.fhi.no/sv/smittsomme-sykdommer/corona/>

## 9 REGISTER, TIMETABLE AND SHIFT

Main Contractor and every single subcontractors are obligated to register the access to the site through Nalanda APP ( Digital Support ). Exceptionally, a crew list must be filling in a daily bases until the Digital support has been implemented on site.

The works-hours of employees also must be registered using the digital support established in their single companies, been after reported to their companies Digital Platform System. The Main Contractor has established a "Works hour´s registration system" to register the man-hours of the workers. The hours register digital system must be chosen freely by each company and/or each worker.

## 10 HSE DIGITAL DEVIATION – SAFETY OBSERVATION CARD.

All the participants along the project are obligated to report all the health and safety deviations.

The HS deviation can be reported through 2 different ways:

- HS digital deviation. A HS deviation will be realized thought the mobile APP named DALUX





- Safety Observation Card. A HS deviation written document will be issued by the participant dropping it in a specific mailbox installed in the facilities for this purpose



Either the HS deviation has been raised by whichever mean, both must be registered in a HS deviation register and must be sent to the Main Contractor in a daily basis.

### 11 EMERGENCY

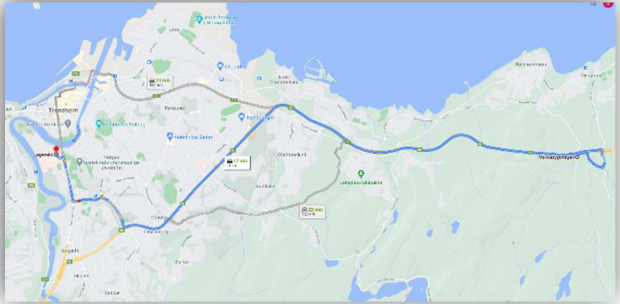
EMERGENCY RESPONSE GUIDE FOR ACCIDENTS		
Minor Accident		
First Aid Kit on Site		
Medical Center  Legevakt Distance:16 Km. Time: 17 min.	 	

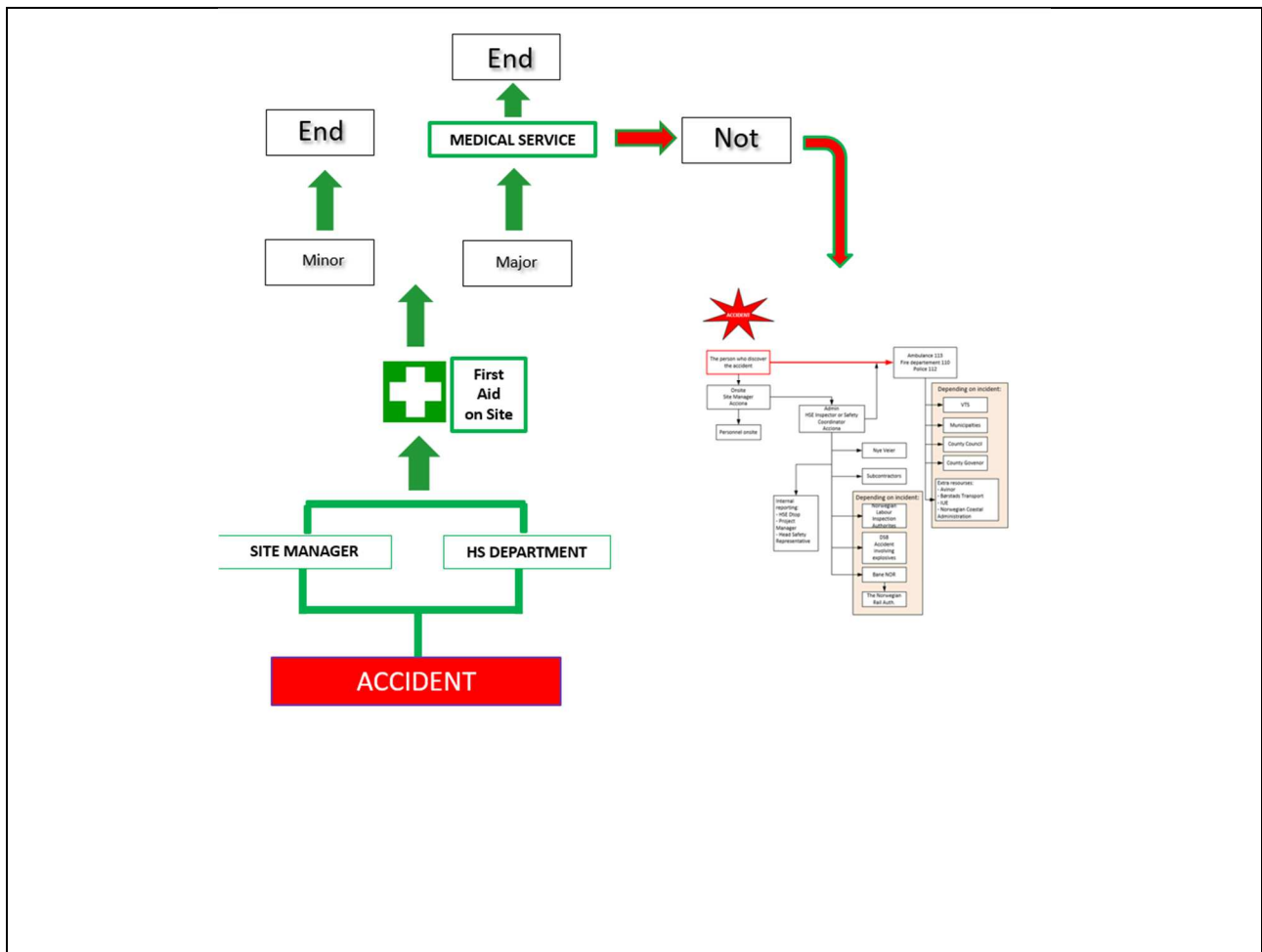

## Major Accident

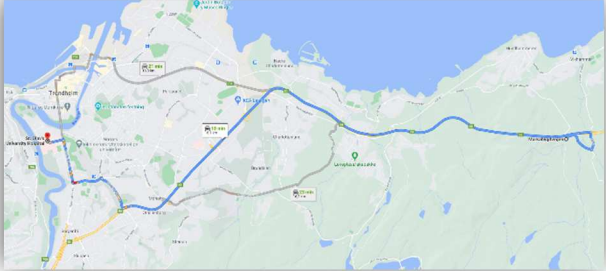
<p><u>Trondheim Hospital</u> St. Olav's University Hospital Distance: 16 km. Time: 18 min.</p>		
--	---	--

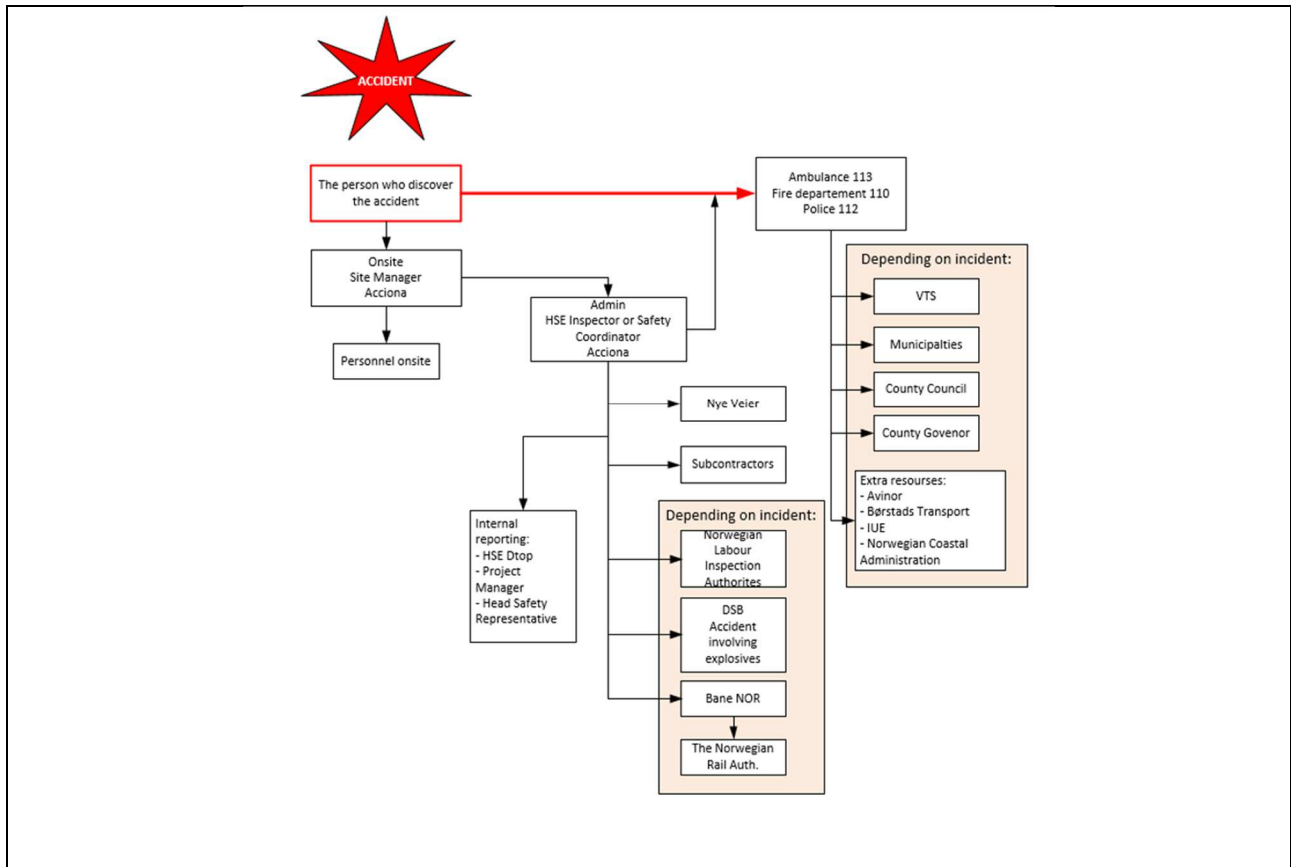

For incident issue refer to Contingency Plan.

## 12 RISK ASSESSMENT / MAIN RISK

It will be provided by subcontractors along the construction stages.

Environmental Aspects and Impacts Register						
SEVERITY (S)		INGREASING PROBABILITY (P)				
		1 Very improbable	2 Improbable	3 Unlikely	4 Likely	5 Certain
1	No impact	1	2	3	4	5
2	Minor impact	2	4	6	8	10
3	Moderate impact	3	6	9	12	15
4	Serious impact	4	8	12	16	20
5	Very serious impact	5	10	15	20	25

UNDER 7
7 - 12
13 AND ABOVE

	Document code	E6RV-ACC-RK-REG-DZ02-0001
	Date	11/11/2020
Landfills Risk Assessment		

GENERAL	ENVIRONMENTAL ASPECT	ENVIRONMENTAL IMPACT	CONDITIONS Normal Abnormal Emergency	PROBABILITY (P) OF IMPACT	SEVERITY (S) OF IMPACT	RISK RATING (R) P x S = R	PREVENTIVE ACTIONS	REVISED PROBABILITY (P <sub>r</sub> ) OF IMPACT	REVISED SEVERITY (S <sub>r</sub> ) OF IMPACT	REVISED RISK RATING (R <sub>r</sub> ) P <sub>r</sub> x S <sub>r</sub> = R <sub>r</sub>
Effects over hydrology	Negative effect on environmental habitats	Changes in the hydrology. Water pollution.	Abnormal	2	3	6	Marking out of the limits for filling and use of sedimentation traps in case of pollution.	1	3	3
Excavators or other vehicles hydraulic hose will burst	Hydraulic oil, grease or fuel will leak to surroundings. Effect on nature and/or water	Hydraulic oil will get to soil or drainage system/natural streams.	Abnormal	4	3	12	Daily inspection of machines, (Special attention to hoses). Warming hydraulic oil enough before starting of works. No working with excavators in very cold weather. Minimize excavation works near drainage or natural waters. Every machine is equipped with leak absorbents. Introduction to site emergency procedures. Always report leaks to Site Manager. Contingency plan for undesirable incidents	3	2	6
Dust from construction activities	Air emissions	Dust may affect local vegetation and waterstreams.	Normal	4	2	8	Design layout in a way that the construction is reasonable and safe, avoiding overconstructing. Use sprayed water to avoid dust during dry conditions.	2	2	4
Storing Chemicals and hazardous materials	Correct way of storing hazardous waste	Waste, ecology	Normal	3	3	9	Chemicals and other hazardous materials shall be handled and stored in such a manner that leakages can not occur (doublelayer containers, storage away from sewage systems, away from places where is traffic, placed in a hard and flat area, etc.).	2	2	4
Landfills runoff	Effects over the ecological condition of water bodies	Leachate and runoff can pollute the water phase with silts, sulfides and nitrates.	Abnormal	4	3	12	Guide walls or intercepting ditches are established to reduce leaching and the amount of leachate from the landfill area. An embankment downstream of the embankment foot will also prevent particulate leachate from the area. Volls will also act as trap ponds. If the leachate contains large amounts of fine particulate matter, the catch pond can be combined with a sand filter, and possibly a silt curtain. If run-off from the landfill area contains oil compounds (oil film), the water will processed in an oil separator before discharge to the sedimentation stage and recipient. According to the Impact assessment. No potentially acid-forming rocks are present in the area, besides continuous monitoring of acid-forming rocks will be performed.	2	2	4
Waste management	Waste and trash escaping to nature	Plastic leftovers from blasting mixed with rocks	Abnormal	4	2	8	Cable wires and detonators will be removed after blasting	2	2	4